



CHIP VANS



1315 Hickman Avenue
Elba, Alabama 36323
334-897-2525

www.dorseytrailer.net

Division of Pitts Enterprises

Features



Construction

High Strength Aluminum with Heavy Duty Steel Bottom Rails

Capacity

100 Cubic Yards

Dimensions

Standard 42' Length - 96" Wide - 13' 1" Tall

Suspension

Hutch - 4 Spring - 3 Point - 56,000 Capacity

Axles

(2) 25K lbs. - 71.5" Track - Hub-Piloted - 30/30 Chambers

Landing Gear

Heavy Duty Two Speed

Floor Sills

Jr. I Beams on 12" / 20" / 12" Centers

Floor Type

Extruded Aluminum .063

Bottom Rail

Heavy Duty Fabricated Steel Rail w/ Bulb Design

Side Sheet Material

.050 Natural Aluminum

Side Posts

Extruded Oval Shaped Aluminum on 16" & 24" Centers

Top Rail

Heavy Duty Extruded Aluminum Rail

Top

Open Top Shown
Closed Top Optional

Tarp System

Std. Cable Pull Mesh Tarp
Roll Top Optional

Tarp Storage

Located at Front of Trailer

Upper Coupler

Integrated full width assembly allows for 180° coupling and uncoupling when necessary.

Ladders

Steel, Front and Rear

Bumper

Heavy Duty Push Bumper

Lights

Sealed Wiring Harness w/L.E.D. Pkg.

Paint

Color Black - 2 Part Polyurethane Primer & Paint

Options: 40' - 57' Lengths, 102" Wide, Walking Floors, Air Ride Suspensions, Single Point Suspensions, Lift Axles, Tire Inflation System, Scales, Aluminum Gate, Winch-Back Landing Gear, and Custom Specifications.

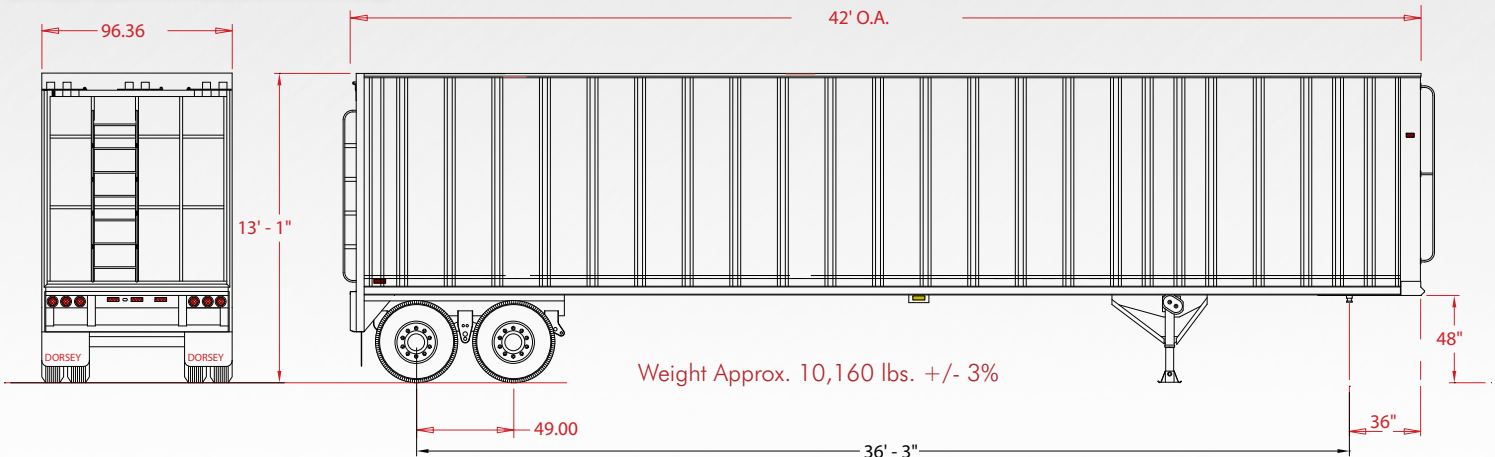

All products, specifications and features, as described or illustrated, are subject to change without notice.